

AMAX-658 AMAX-637 AMAX-657

Real-time SoftLogic Programmable Edge Controller



Features

- CODESYS Control Real Time Engine (RTE) & Visualization (Target & Web)
- Embedded OS with optimized BIOS adjustment for real-time demand
- Support CODESYS Redundancy (optional license, supported from SP18)
- Supports IEC-61131-3 PLCopen languages (FBD, LD, IL, ST, and SFC)
- Upstream connectivity IT/OT communication (MQTT, OPC UA, and ODBC)
- Supports EtherCAT, ProfiNet, Ethernet/IP, and Modbus TCP/RTU protocols
- Local AMAX-5000 series EtherCAT IO expansion module
- Online upgrade of SoftMotion and CNC Robotics license from Advantech WISE-Marketplace
- Advantech CODESYS Agent integrated third party software for data transmission via symbols (PLC Handler) and shared memory (C/C++/C#)



Introduction

AMAX-658/637/657 real-time edge controllers powered by CODESYS, control kernel Soft-PLC equipped with Industrial Ethernet and Fieldbus for OT applications. Support for IEC-61131-3 programming languages enables engineers to easily program PLCs and SoftMotion and CNC Robotics modules for various motion control applications. To provide comprehensive control solutions, Advantech also offers flexible expansion options, including industrial Ethernet I/O, peripheral I/O, slice I/O, and distributed I/O modules.

Moreover, to ensure easy data access with IT-OT integration, uplink connectivity with MQTT, OPC UA and ODBC (database) via Advantech CODESYS add-on and CODESYS agent service developed by team.

Also we integrated platform diagnosis information like CPU temp, usage...etc with CODESYS environment to enhance product reliability. Furthermore, Advantech's WISE-PaaS platform can be leveraged for field-side management to enhance productivity and equipment flexibility.

Specifications

Model	AMAX-637	AMAX-657		AMAX-658			
Part Number	AMAX-637-E1CW00A	AMAX-657-E2CW00A	AMAX-657-E2CW0RA	AMAX-658-6CCW00A	AMAX-658-65CW00A	AMAX-658-67CW00A	
SoftLogic	Runtime	CODESYS Control RTE V3.5					
	Visualization	Target Visualization (Local HMI), Web Visualization (Web Browser)					
	Industrial Fieldbus Protocol	EtherCAT MainDevice, PROFINET IO-Controller, EtherNet/IP Scanner (IEC/CIFX), MODBUS/TCP Server (Slave) and Client (Master), MODBUS/RTU Client (Master) PROFIBUS Master & CANopen Manager (optional by expansion module)					
	Uplink communication	OPC UA Server, MQTT (Sparkplug), ODBC for Database(Via Advantech CODESYS installation package)					
	Advance Motion Control	SoftMotion & CNC Robotic (Optional-Upgrade from Advantech WISE-Marketplace)					
System Hardware	Motion Control Capability	32-axis with 1ms cycle time	64-axis with 1ms cycle time	64-axis with 1ms cycle time	128-axis with 1ms cycle time	256-axis with 1ms cycle time	
	Processor	Intel® Atom™ 1.2GHz	Intel® Atom™ 1.5GHz		Intel® Celeron 2.0GHz	Intel® Core™ i5 2.4GHz	Intel® Core™ i7 2.6GHz
	Memory	8GB	4GB		4G	8G	8G
	Storage	128GB SSD	64GB eMMC		128GB SSD		
	Retain Memory*	NVRAM (2MB/4MB)	-	NVRAM (2MB/4MB)	NVRAM (2MB/4MB)		
I/O Interfaces	Expansion	1 x 2.5" SSD/HDD slot	1 x mPCIe 1 x M.2 B-Key AMAX-5000 Slice I/O modules	1 x M.2 B-Key AMAX-5000 Slice I/O module	AMAX-5400 PCIe modules (max.4) AMAX-5000 Slice I/O modules		
	Power Supply	10-36V	DC24V ± 20%		DC24V ± 20%		
	Local Digital IO	8 Digital Input (Wet/Dry), 8 Digital Output (Sink)	-		-		
	Serial Ports	2 x RS-232/422/485 (terminal)	1 x RS-232/422/485, 1 x 485 (terminal) 2 x CAN Bus (terminal)		2 x RS-232/422/485 (DB9)		
	LAN Ports	2 x RJ45, 10/100/1000 Mbps IEEE 802.3u 1000BASE-T	2 x RJ45, 10/100/1000 Mbps IEEE 802.3u 1000BASE-T		2 x RJ45, 10/100/1000 Mbps IEEE 802.3u 1000BASE-T		
	Display	2 x DP 1.2	1 x HDMI		1 x VGA 1 x HDMI		
	Isolation	DI & DO & Serial Ports (2500VDC)	CAN & Serial Port isolation (500VDC)		-		
Environment	Grounding Protection	Chassis grounding	Chassis grounding	No ground isolation	Chassis grounding		
	Operation Temperature	-40 ~ 60°C	-20~60°C		-10 ~60°C		
	Dimension (W x H x D)	75 x 150 x 105mm	48.8 x 100 x 70mm		139 x 100 x 80mm		
Approval	CE, UL61010, BSMI, CCC	CE, UL61010, BSMI		CE, UL62368, BSMI			

* 4MB only supported for CODESYS version newer than SP18

Dimensions

Unit: mm

AMAX-658

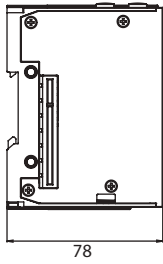

AMAX-5400 Expansion Module

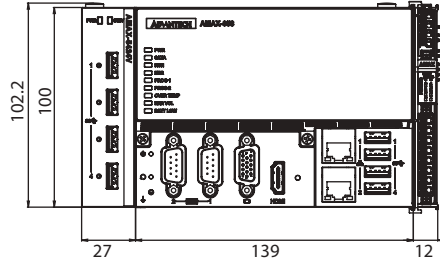

AMAX-658 Controller with Expansion

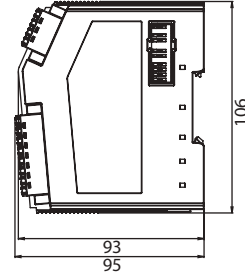

AMAX-5000 EtherCAT Slice I/O Module

AMAX-637

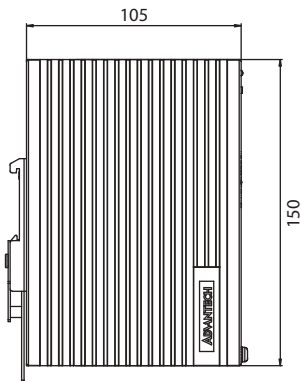

AMAX-657

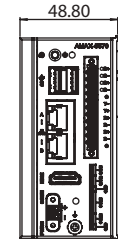
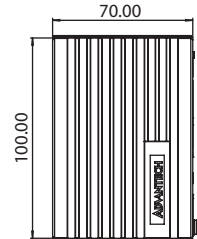
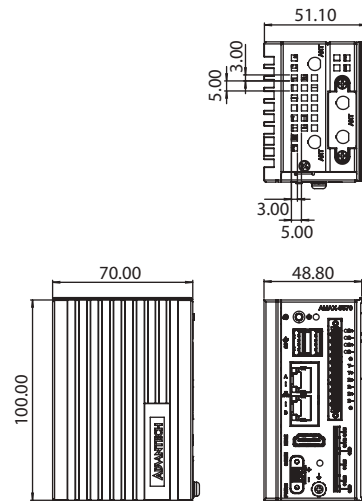
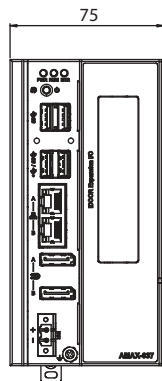

Ordering Information

Soft Logic Controller

- **AMAX-658-6CCW00A** AMAX-5580-C, 4GRAM/128G, W10CDS RTE&Vis, w/ Retain
- **AMAX-658-65CW00A** AMAX-5580-5, 8GRAM/128G, W10CDS RTE&Vis, w/ Retain
- **AMAX-658-67CW00A** AMAX-5580-7, 8GRAM/128G, W10CDS RTE&Vis, w/ Retain
- **AMAX-637-E1CW00A** UNO-137 with iDoorExp, 8GRAM/128G, W10CDS RTE&Vis, w/ Retain
- **AMAX-657-E2CW00A** AMAX-5570, 4GRAM/64G, W10CDS RTE&Vis, w/o Retain
- **AMAX-657-E2CW0RA** AMAX-5570, 4GRAM/64G, W10CDS RTE&Vis, w/ Retain

CODESYS Function Extended License

- **360TCDSW00SMA0** CDS V3 License SoftMotion
- **360TCDSW0CNCA0** CDS V3 License CNC Robotics
- **360TCDSW0CNCA2** CDS V3 License Softmotion + CNC
- **360TCDSWREDNA0** CDS V3 License Redundancy

EtherCAT I/O Modules

AMAX-658 must add 1pc AMAX-5001 as beginning power module. AMAX-657 can leverage controller power to supply 1A current for modules. AMAX-637 can only Add AMAX-5074 as extending structure.

AMAX-5000 Fieldbus Communication coupler/module

- **AMAX-5074** EtherCAT coupler
- **AMAX-5070** Modbus/TCP Coupler with ID Switch Coupler
- **AMAX-5072** EtherNet/IP Coupler with ID Switch Coupler
- **AMAX-5079** EtherCAT extension module

AMAX-5000 EtherCAT Module

- **AMAX-5001** Power Input with 4-ch DI Module
- **AMAX-5015** 4-ch RTD Input Module
- **AMAX-5017C** 6-ch Current Analog Input Module
- **AMAX-5017H** 4-ch High Speed Analog Input Module
- **AMAX-5017V** 6-ch Voltage Analog Input Module
- **AMAX-5018** 6-ch Thermocouple Input Module
- **AMAX-5024** 4-ch Analog Output Module
- **AMAX-5051** 8-ch Digital Input Module
- **AMAX-5051T** 2-ch DI Timestamp, 6-ch DI w/o Timestamp Module
- **AMAX-5052** 16-ch Digital Input Module
- **AMAX-5056** 8-ch Sink Type Digital Output Module
- **AMAX-5056SO** 8-ch Source Type Digital Output Module
- **AMAX-5056T** 2-ch DO Timestamp Module
- **AMAX-5057** 16-ch Sink Type Digital Output Module
- **AMAX-5057SO** 16-ch Source Type Digital Output Module
- **AMAX-5060** 4-ch Relay with 2-ch Digital Input Module
- **AMAX-5080** 2-ch 24V HTL Incremental Encoder/Counter Module
- **AMAX-5081** 1-ch TTL/RS-422 Incremental Encoder/Counter Module
- **AMAX-5082** 1-ch SSI Absolute Encoder Module
- **AMAX-5086** 2-ch PWM with 2-ch Digital Input Module
- **AMAX-5090** 1-ch RS-232/422/485 Serial Port Module

PCIe Expansion Modules (Only for AMAX-658)

AMAX-5400 PCIe Expansion Module

- **AMAX-5400E** PCIe-mini card with SIM card slot
- **AMAX-5410** 2 x GigE expansion module
- **AMAX-5410P** 2 x PoE expansion module
- **AMAX-5424V** 4 x USB 3.0 with full bandwidth
- **AMAX-5490** 2 x isolated RS-232/422/485
- **AMAX-5495** 2 x CAN module
- **AMAX-5493M** 1 x Profibus-DP module

Accessories

DIN-Rail Type AC-to-DC Power Supply

- **96PSD-A60W24-MM** A/D 100 ~ 240V, 60W, 24V, MDR, DIN-Rail
- **96PSD-A120W24-MN** A/D 100 ~ 240V, 120W, 24V, NDR, DIN-Rail