

EDS-408A Series

8-port entry-level managed Ethernet switches

Vertrieb durch



AMC – Analytik & Messtechnik GmbH Chemnitz

Heinrich-Lorenz-Str. 55 Tel.: +49/371/38388-0
09120 Chemnitz Fax: +49/371/38388-99
E-Mail: info@amc-systeme.de Web: www.amc-systeme.de



Features and Benefits

- Turbo Ring and Turbo Chain (recovery time < 20 ms @ 250 switches), and RSTP/STP for network redundancy
- IGMP Snooping, QoS, IEEE 802.1Q VLAN, and port-based VLAN supported
- Easy network management by web browser, CLI, Telnet/serial console, Windows utility, and ABC-01
- PROFINET or EtherNet/IP enabled by default (PN or EIP models)
- Supports MXstudio for easy, visualized industrial network management

Certifications



Introduction

The EDS-408A Series is designed especially for industrial applications. The switches support a variety of useful management functions, such as Turbo Ring, Turbo Chain, ring coupling, IGMP snooping, IEEE 802.1Q VLAN, port-based VLAN, QoS, RMON, bandwidth management, port mirroring, and warning by email or relay. The ready-to-use Turbo Ring can be set up easily using the web-based management interface, or with the DIP switches located on the top panel of the EDS-408A switches.

Additional Features and Benefits

- DHCP Option 82 for IP address assignment with different policies
- Supports EtherNet/IP, Modbus TCP and PROFINET¹ protocols for device management and monitoring
- EtherNet/IP EDS (Electronic Data Sheet) file, custom AOI (Add-On Instructions) and FactoryTalk® View faceplate available
- PROFINET GSDML file and SIMATIC STEP 7 device icons available¹
- Port mirroring for online debugging
- Port-based VLAN, IEEE 802.1Q VLAN, and GVRP to ease network planning
- QoS (IEEE 802.1p and TOS/DiffServ) to increase determinism
- RMON for proactive and efficient network monitoring
- SNMPv1/v2c/v3 for different levels of network management security
- Bandwidth management to prevent unpredictable network status

Specifications

Ethernet Interface

10/100BaseT(X) Ports (RJ45 connector)	EDS-408A/408A-T, EDS-408A-EIP/PN Series: 8 EDS-408A-MM-SC/MM-ST/SS-SC Series: 6 EDS-408A-3M-SC/3M-ST/3S-SC/3S-SC-48/1M2S-SC/2M1S-SC Series: 5 All models support: Auto negotiation speed Full/Half duplex mode Auto MDI/MDI-X connection
100BaseFX Ports (multi-mode SC connector)	EDS-408A-MM-SC/2M1S-SC Series: 2 EDS-408A-3M-SC Series: 3 EDS-408A-1M2S-SC Series: 1
100BaseFX Ports (multi-mode ST connector)	EDS-408A-MM-ST Series: 2 EDS-408A-3M-ST Series: 3
100BaseFX Ports (single-mode SC connector)	EDS-408A-SS-SC/1M2S-SC Series: 2 EDS-408A-2M1S-SC Series: 1 EDS-408A-3S-SC/3S-SC-48 Series: 3

1. EDS-408A-PN Series only

Standards	IEEE 802.3 for 10BaseT IEEE 802.3u for 100BaseT(X) and 100BaseFX IEEE 802.3x for flow control IEEE 802.1D-2004 for Spanning Tree Protocol IEEE 802.1p for Class of Service IEEE 802.1Q for VLAN Tagging IEEE 802.1w for Rapid Spanning Tree Protocol
-----------	--

Optical Fiber			100BaseFX		
			Multi-Mode	Single-Mode	
	Fiber Cable Type		OM1	50/125 µm	G.652
				800 MHz x km	
	Typical Distance		4 km	5 km	40 km
	Wavelength	Typical (nm)		1300	
		TX Range (nm)		1260 to 1360	
		RX Range (nm)		1100 to 1600	
	Optical Power	TX Range (dBm)		-10 to -20	
		RX Range (dBm)		-3 to -32	
		Link Budget (dB)		12	
		Dispersion Penalty (dB)		3	
Note: When connecting a single-mode fiber transceiver, we recommend using an attenuator to prevent damage caused by excessive optical power. Note: Compute the "typical distance" of a specific fiber transceiver as follows: Link budget (dB) > dispersion penalty (dB) + total link loss (dB).					

Ethernet Software Features	
Filter	802.1Q VLAN, GMRP, GVRP, IGMP v1/v2, Port-based VLAN
Industrial Protocols	EtherNet/IP, Modbus TCP, EDS-408A-PN Series: PROFINET IO Device (Slave)
Management	Back Pressure Flow Control, BOOTP, DHCP Option 66/67/82, DHCP Server/Client, Flow control, IPv4/IPv6, LLDP, Port Mirror, RARP, RMON, SMTP, SNMP Inform, SNMPv1/v2c/v3, Syslog, Telnet, TFTP
MIB	Bridge MIB, Ethernet-like MIB, MIB-II, P-BRIDGE MIB, RMON MIB Groups 1, 2, 3, 9, RSTP MIB
Redundancy Protocols	RSTP, STP, Turbo Chain, Turbo Ring v1/v2
Time Management	NTP Server/Client, SNTP

Switch Properties	
IGMP Groups	256
MAC Table Size	8 K
Max. No. of VLANs	64
Packet Buffer Size	1 Mbits
Priority Queues	4
VLAN ID Range	VID 1 to 4094

Serial Interface	
Console Port	RS-232 (TxD, RxD, GND), 10-pin RJ45 (19200, n, 8, 1)

DIP Switch Configuration

Ethernet Interface	Turbo Ring, Master, Coupler, Reserve
Input/Output Interface	
Alarm Contact Channels	Relay output with current carrying capacity of 1 A @ 24 VDC
Power Parameters	
Connection	1 removable 6-contact terminal block(s)
Input Voltage	All models: Redundant dual inputs EDS-408A/408A-T, EDS-408A-MM-SC/MM-ST/SS-SC/3M-SC/3M-ST/3S-SC/1M2S-SC/ 2M1S-SC/EIP/PN Series: 12/24/48 VDC EDS-408A-3S-SC-48/408A-3S-SC-48-T: $\pm 24/\pm 48$ VDC
Operating Voltage	EDS-408A/408A-T, EDS-408A-MM-SC/MM-ST/SS-SC/3M-SC/3M-ST/3S-SC/1M2S-SC/ 2M1S-SC/EIP/PN Series: 9.6 to 60 VDC EDS-408A-3S-SC-48 Series: ± 19 to ± 60 VDC ²
Input Current	EDS-408A/408A-T, EDS-408A-EIP/PN Series: 0.18 A @ 24 VDC EDS-408A-MM-SC/MM-ST/SS-SC Series: 0.30 A @ 24 VDC EDS-408A-3M-SC/3M-ST/3S-SC/3S-SC-48/1M2S-SC/2M1S-SC Series: 0.35 A @ 24 VDC
Overload Current Protection	Supported
Reverse Polarity Protection	Supported
Physical Characteristics	
Housing	Metal
IP Rating	IP30
Dimensions	53.6 x 135 x 105 mm (2.11 x 5.31 x 4.13 in)
Weight	EDS-408A/408A-T, EDS-408A-MM-SC/MM-ST/SS-SC, EDS-408A-EIP/PN Series: 650 g (1.44 lb) EDS-408A-3M-SC/3M-ST/3S-SC/3S-SC-48/1M2S-SC/2M1S-SC Series: 890 g (1.97 lb)
Installation	DIN-rail mounting, Wall mounting (with optional kit)
Environmental Limits	
Operating Temperature	Standard Models: -10 to 60°C (32 to 140°F) Wide Temp. Models: -40 to 75°C (-40 to 167°F)
Storage Temperature (package included)	-40 to 85°C (-40 to 185°F)
Ambient Relative Humidity	5 to 95% (non-condensing)
Standards and Certifications	
Safety	All models: EN 60950-1, UL 508 EDS-408A/408A-T, EDS-408A-MM-SC/MM-ST/SS-SC Series, EDS-EIP/PN Series: UL 60950-1
EMC	EN 55032/24
EMI	CISPR 32, FCC Part 15B Class A
EMS	IEC 61000-4-2 ESD: Contact: 6 kV; Air: 8 kV IEC 61000-4-3 RS: 80 MHz to 1 GHz: 10 V/m IEC 61000-4-4 EFT: Power: 2 kV; Signal: 2 kV IEC 61000-4-5 Surge: Power: 2 kV; Signal: 2 kV IEC 61000-4-6 CS: 10 V

2. ² -60 to -19 VDC or 19 to 60 VDC. Do not mix power polarity systems.

	IEC 61000-4-8 PFMF
Hazardous Locations	EDS-408A/408A-T, EDS-408A-MM-SC/MM-ST/SS-SC Series, EDS-408A-EIP/PN Series: ATEX, Class I Division 2
Maritime	EDS-408A/408A-T, EDS-408A-MM/SS Series: NK EDS-408A/408A-T, EDS-408A-MM/SS Series, EDS-408A-EIP/PN Series: DNV-GL
Railway	EN 50121-4
Traffic Control	NEMA TS2
Freefall	IEC 60068-2-31
Shock	IEC 60068-2-27
Vibration	IEC 60068-2-6

MTBF

Time	EDS-408A/408A-T, EDS-408A-EIP/PN Series: 1,339,439 hrs EDS-408A-MM-SC/MM-ST/SS-SC/3M-SC/3M-ST/3S-SC/1M2S-SC/2M1S-SC Series: 1,253,072 hrs EDS-408A-3S-SC-48 Series: 989,940 hrs
Standards	Telcordia (Bellcore), GB

Warranty

Warranty Period	5 years
Details	See www.moxa.com/warranty

Package Contents

Device	1 x EDS-408A Series switch
Cable	1 x RJ45-to-DB9 console cable
Installation Kit	4 x cap, plastic, for RJ45 port
Documentation	1 x product certificates of quality inspection, Simplified Chinese 1 x product notice, Simplified Chinese 1 x quick installation guide 1 x warranty card

Vertrieb durch



AMC – Analytik & Messtechnik GmbH Chemnitz

Heinrich-Lorenz-Str. 55 Tel.: +49/371/38388-0
09120 Chemnitz Fax: +49/371/38388-99
E-Mail: info@amc-systeme.de Web: www.amc-systeme.de

Dimensions

Unit: mm (inch)

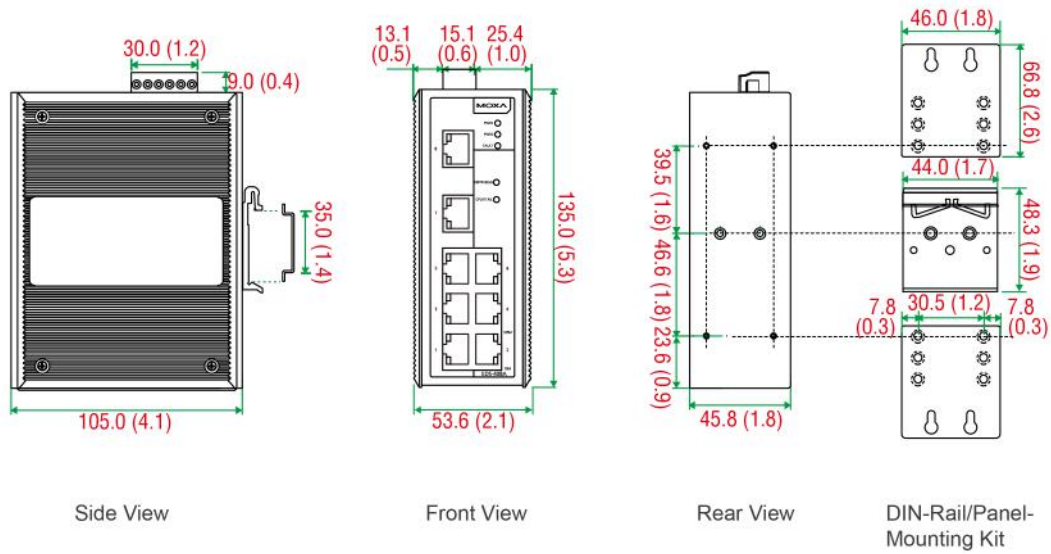

Ordering Information

Model Name	Layer	Total No. of Ports	10/100BaseT(X) Ports RJ45 Connector	100BaseFX Ports Multi-Mode, SC Connector	100BaseFX Ports Multi-Mode, ST Connector	100BaseFX Ports Single-Mode, SC Connector	Operating Temp.
EDS-408A	2	8	8	-	-	-	-10 to 60°C
EDS-408A-T	2	8	8	-	-	-	-40 to 75°C
EDS-408A-MM-ST	2	8	6	-	2	-	-10 to 60°C
EDS-408A-MM-ST-T	2	8	6	-	2	-	-40 to 75°C
EDS-408A-MM-SC	2	8	6	2	-	-	-10 to 60°C
EDS-408A-MM-SC-T	2	8	6	2	-	-	-40 to 75°C
EDS-408A-SS-SC	2	8	6	-	-	2	-10 to 60°C
EDS-408A-SS-SC-T	2	8	6	-	-	2	-40 to 75°C
EDS-408A-3M-ST	2	8	5	-	3	-	-10 to 60°C
EDS-408A-3M-ST-T	2	8	5	-	3	-	-40 to 75°C
EDS-408A-3M-SC	2	8	5	3	-	-	-10 to 60°C
EDS-408A-3M-SC-T	2	8	5	3	-	-	-40 to 75°C
EDS-408A-3S-SC	2	8	5	-	-	3	-10 to 60°C
EDS-408A-3S-SC-T	2	8	5	-	-	3	-40 to 75°C
EDS-408A-3S-SC-48	2	8	5	-	-	3	-10 to 60°C
EDS-408A-3S-SC-48-T	2	8	5	-	-	3	-40 to 75°C
EDS-408A-1M2S-SC	2	8	5	1	-	2	-10 to 60°C
EDS-408A-1M2S-SC-T	2	8	5	1	-	2	-40 to 75°C
EDS-408A-2M1S-SC	2	8	5	2	-	1	-10 to 60°C
EDS-408A-2M1S-SC-T	2	8	5	2	-	1	-40 to 75°C

Model Name	Layer	Total No. of Ports	10/100BaseT(X) Ports RJ45 Connector	100BaseFX Ports Multi-Mode, SC Connector	100BaseFX Ports Multi-Mode, ST Connector	100BaseFX Ports Single-Mode, SC Connector	Operating Temp.
EDS-408A-EIP	2	8	8	–	–	–	-10 to 60°C
EDS-408A-EIP-T	2	8	8	–	–	–	-40 to 75°C
EDS-408A-PN	2	8	8	–	–	–	-10 to 60°C
EDS-408A-PN-T	2	8	8	–	–	–	-40 to 75°C

Accessories (sold separately)

Storage Kits

ABC-01	Configuration backup and restoration tool for managed Ethernet switches and AWK Series wireless APs/bridges/clients, 0 to 60°C operating temperature
--------	--

Power Supplies

DR-120-24	120W/2.5A DIN-rail 24 VDC power supply with universal 88 to 132 VAC or 176 to 264 VAC input by switch, or 248 to 370 VDC input, -10 to 60°C operating temperature
DR-4524	45W/2A DIN-rail 24 VDC power supply with universal 85 to 264 VAC or 120 to 370 VDC input, -10 to 50°C operating temperature
DR-75-24	75W/3.2A DIN-rail 24 VDC power supply with universal 85 to 264 VAC or 120 to 370 VDC input, -10 to 60°C operating temperature
MDR-40-24	DIN-rail 24 VDC power supply with 40W/1.7A, 85 to 264 VAC, or 120 to 370 VDC input, -20 to 70°C operating temperature
MDR-60-24	DIN-rail 24 VDC power supply with 60W/2.5A, 85 to 264 VAC, or 120 to 370 VDC input, -20 to 70°C operating temperature

Wall-Mounting Kits

WK-46-01	Wall-mounting kit, 2 plates, 8 screws, 46 x 66.8 x 2 mm
----------	---

Rack-Mounting Kits

RK-4U	19-inch rack-mounting kit
-------	---------------------------

Software

MXview-50	Industrial network management software with a license for 50 nodes (by IP address)
MXview-100	Industrial network management software with a license for 100 nodes (by IP address)
MXview-250	Industrial network management software with a license for 250 nodes (by IP address)
MXview-500	Industrial network management software with a license for 500 nodes (by IP address)
MXview-1000	Industrial network management software with a license for 1000 nodes (by IP address)
MXview-2000	Industrial network management software with a license for 2000 nodes (by IP address)
MXview Upgrade-50	License expansion of MXview industrial network management software by 50 nodes (by IP address)

© Moxa Inc. All rights reserved. Updated Aug 06, 2019.

This document and any portion thereof may not be reproduced or used in any manner whatsoever without the express written permission of Moxa Inc. Product specifications subject to change without notice. Visit our website for the most up-to-date product information.